

T. F. VANDEGRIFT.
BELT TIGHTENER AND SHIFTER.

No. 512,850.

Patented Jan. 16, 1894.

Fig. 1.

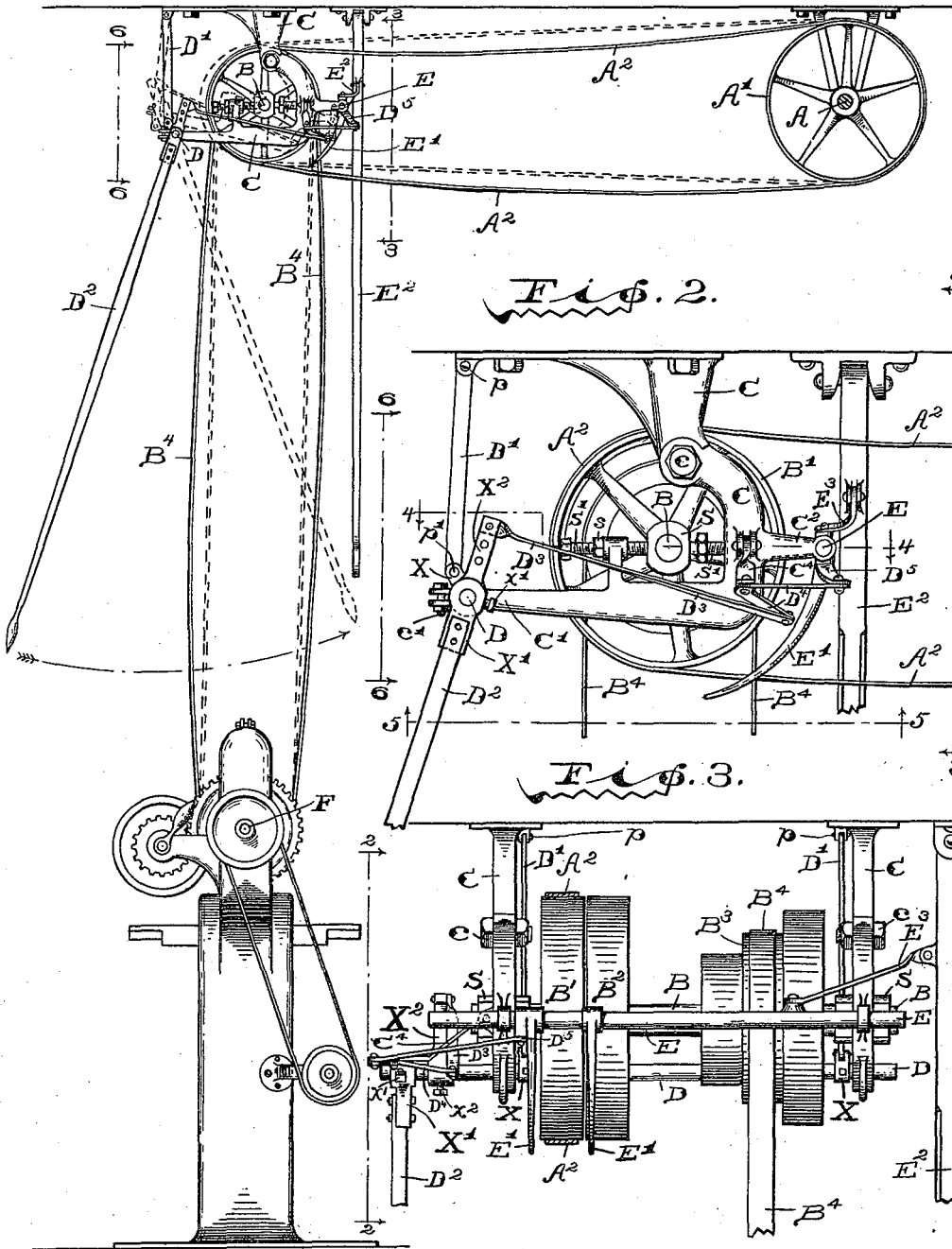

WITNESSES:

F. W. Warner.
J. Walsh.

INVENTOR

Theodore F. Vandegrift,

BY *Chester Bradford,*
ATTORNEY.

T. F. VANDEGRIFT.
BELT TIGHTENER AND SHIFTER.

No. 512,850.

Patented Jan. 16, 1894.

FIG. 4.

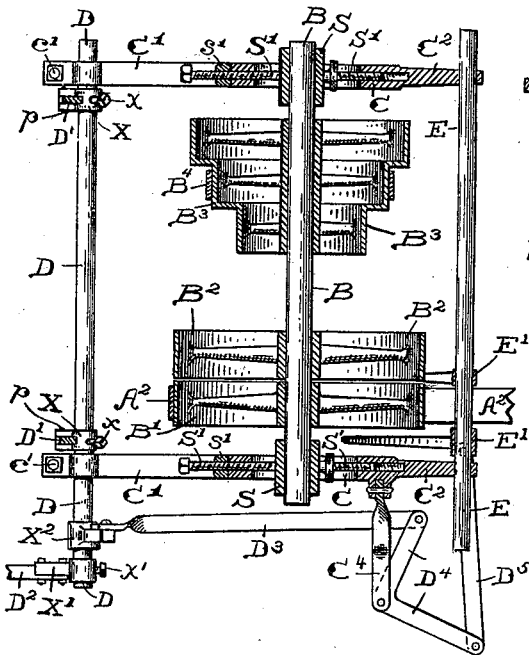

FIG. 5.

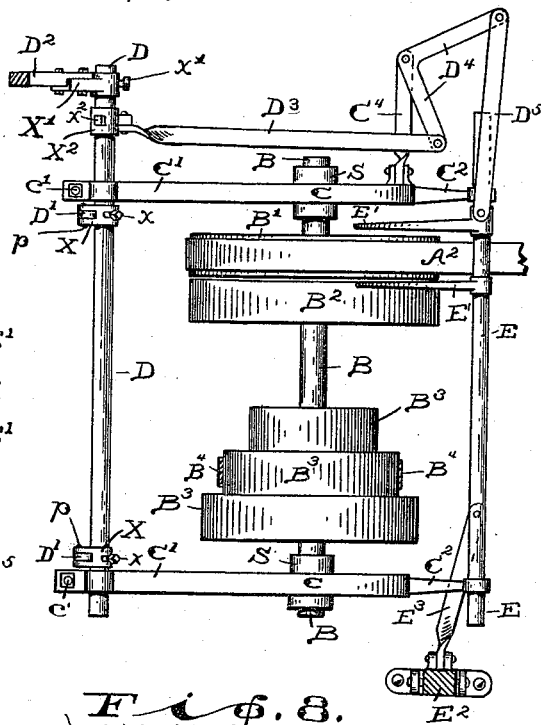

FIG. 6.

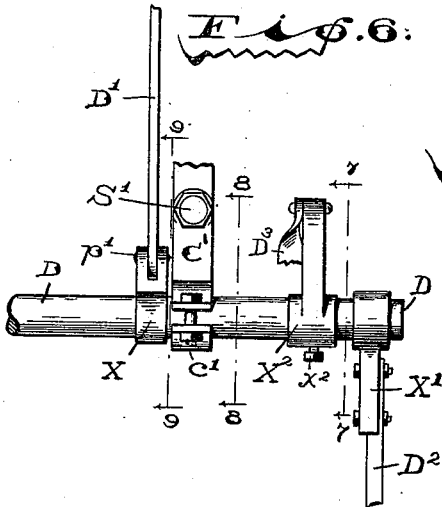

FIG. 8.

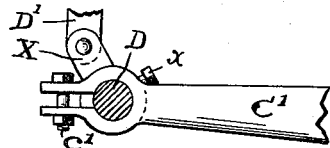

FIG. 7.

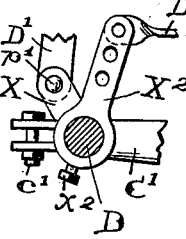
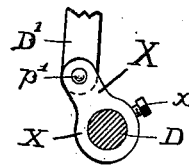

FIG. 9.



WITNESSES:

J. N. Warner.
J. Walsh.

INVENTOR
Theodore F. Vandegrift,
BY
Chester Bradford,
ATTORNEY.

UNITED STATES PATENT OFFICE.

THEODORE F. VANDEGRIFT, OF SHELBYVILLE, INDIANA.

BELT TIGHTENER AND SHIFTER.

SPECIFICATION forming part of Letters Patent No. 512,850, dated January 16, 1894.

Application filed July 22, 1893. Serial No. 481,180. (No model.)

To all whom it may concern:

Be it known that I, THEODORE F. VANDEGRIFT, a citizen of the United States, residing at Shelbyville, in the county of Shelby and State of Indiana, have invented certain new and useful Improvements in Belt Slackening and Shifting Mechanism, of which the following is a specification.

In the operation of that class of machines which are intermittingly put in use, such as lathes, &c., wherein the usual means of starting and stopping is by the shifting of a belt from a "tight" to a "loose" pulley, the continual running of the loose pulley upon the shaft is, under the tension of the belt, apt to wear into that side of the shaft opposite the pull of the belt, and thus, besides imparing the shaft, render the surfaces of the two pulleys unequal.

The object of my invention is to provide a means whereby the belt may be slackened, as well as shifted, thus reducing the force of the pull on pulley and shaft and obviating the disadvantages above mentioned. A mechanism embodying said invention will first be fully described, and the novel features thereof then specifically pointed out in the claims.

Referring to the accompanying drawings, which are made a part hereof, and on which similar letters of reference indicate similar parts, Figure 1 is an end elevation of a lathe and the driving shaft and counter shaft from which it is driven, with my invention embodied in the counter shaft hangings and attachments; Fig. 2 a detail end elevation of the counter shaft and its said hangings and attachments, on an enlarged scale; Fig. 3 a detail elevation as seen from the dotted lines 3 3 in Figs. 1 and 2; Fig. 4 a horizontal sectional view looking downwardly from the dotted line 4 4 in Fig. 2; Fig. 5 an under side plan as seen when looking upwardly from the dotted line 5 5 below Fig. 3; Fig. 6 a detail elevation on a further enlarged scale of a portion of the rock-shaft and attachments as seen from the dotted lines 6 6 in Figs. 1 and 2, and Figs. 7, 8 and 9 detail views as seen from the dotted lines 7 7, 8 8 and 9 9 in Figs. 4 and 6.

In said drawings the portions marked A represent the driving shaft; B the counter

shaft; C the hanger for said counter shaft; D a rock-shaft whereby said hanger is operated; E the rod of the belt shifter, and F the shaft of the lathe or other tool or machine to be operated or driven.

The driving shaft A is or may be mounted and driven in any ordinary manner, and upon it is the pulley A' from which a belt A² runs to the tight and loose pulleys on the counter shaft B, all in the ordinary and well known manner.

The counter shaft B is an ordinary counter shaft, and is mounted in suitable bearings S in the hangers C, and carries the tight and loose pulleys B' and B² by which it is driven from the pulley A' by the belt A², and also a cone or other pulley B³ by which it, when thrown into operation, through a belt B⁴ drives the tool or mechanism to be operated, all, generally speaking, in the usual and well known manner. The position of the counter shaft is adapted to be shifted, however, by my peculiar mechanism, to achieve the object of my invention. The different positions of the parts are shown in Fig. 1 wherein the tight or operative position of the belts and mechanism is shown by means of dotted lines, and the slack or out of operation position of said belts and other parts is shown by means of full lines, except that the belt B⁴ is shown bowed out or swung apart somewhat more than it would naturally do, in order that the dotted and full lines may be more clearly separated. The bearings S in which the counter shaft B is mounted are or may be in themselves of an ordinary character. They are mounted upon adjustable supporting screws S', whereby they are adapted to be shifted somewhat from side to side, and jam nuts s secure them in adjusted position. All this, so far as the construction is concerned, is common and well known, but it has a special function in connection with my invention. Obviously, said invention is to be applied under varying circumstances, and where the proportional lengths of the belts A² and B⁴ vary considerably. It is therefore desirable that the movement of my device, in tightening and slackening the belts, should correspondingly vary. This is achieved by varying the relative position of the shaft B to the

pivots c , which may readily be done by means of the supporting screws S' , thus shifting the boxes S , carrying the counter shaft B back and forth below the pivots c . What is, therefore, an ordinary mechanical contrivance in its construction, is thus, in my invention, made to achieve a new result.

The hanger C is composed of two parts connected together by a pivot bolt c . The upper part is secured to the ceiling or framework of the shop or apartment where the mechanism is located, in an ordinary and well known manner, while the lower part is adapted to have a limited movement upon the pivot c . As shown in Fig. 2, the union is preferably of the "rule joint" variety in order to prevent this hanger from having too great a backward movement. Obviously, however, a stop might be provided which would serve the purpose equally well. The pivot bolts c which pass through these joints are adapted to be tightened up sufficiently so that the friction will hold the parts to the position to which they are swung by the lever. There are, of course, two of these hangers, and each of them, besides being provided with suitable supports for the bearings for the counter shaft, has two arms. In the arms C' are bearings for the rock-shaft D , and in the arms C^2 are bearings for the the belt-shifter rod E .

The rock-shaft D is mounted in bearings in the extreme ends or arms C' of the hanger C , and is suspended from the ceiling or upper portion of the hangers by links D' . These links are hung upon the pivots p , and are connected to short arms or cranks X upon the shaft D by pivots p' , and thus support and guide said shaft in its movements. It is necessary to vary the movement of the rock-shaft D from time to time, as the belt is stretched in use, or in fitting up the apparatus originally for operation. The crank arms X are therefore adjustably secured on said rock-shaft, preferably by means of set screws x , so that they may be turned on said rock shaft as may be required. Another arm X' provided with a set screw x' serves as a means whereby the operating lever D^2 may be attached to said shaft D , and whereby it may be adjusted thereon from time to time, so that, as the shaft is adjusted, the lever may also be adjusted to convenient positions for the operator. Moving this lever obviously rocks the rock shaft in its bearings, and as said rock shaft is supported by the links D' and crank arms X , the result is to swing the lower portion of the hangers C on their pivots from the position shown in full lines in Fig. 1 to the position shown in dotted lines in said figure, and this, being both a backward and an upward movement, tightens both the belts A^2 and B^4 . The shaft B also has another arm X^2 thereon, which is likewise capable of adjustment, by means of the set screw x^2 , and this is connected to the belt-shifter-rod E by means of a link D^3 , a bell crank lever D^4 , and a link D^5 ,—the bell crank

lever D^4 being connected to the hanger C by a pivoted arm C^4 ,—and thus the belt shifter is operated at the same time the belt slackener is operated, as will be readily understood by an examination of the drawings. The arms C' of the hangers in which are the bearings for the rock shaft D are shown as split and adapted to be clamped together by bolts c' . By this means any required amount of friction may be had between the rock shaft and its bearings. The friction upon the rock shaft at these bearings is sufficient to hold the parts to any position to which they may be moved by means of the lever D^2 , and of course may be regulated at pleasure by tightening or loosening the bolts c' .

The belt-shifter rod E is mounted in bearings in the arms C^2 on the hanger C , and is provided with the usual belt shifting arms E' , and is operated by an ordinary lever E^2 pivoted to the ceiling or otherwise, and connected to the rod E by a link E^3 . By means of the lever E^2 the belt shifter can be operated in the ordinary manner, as well as by means of the belt slackener. When the belt shifter is used, the belt-slackener mechanism is detached therefrom, by uncoupling the link D^3 from the arm X^2 .

Having thus fully described my said invention, what I claim as new, and desire to secure by Letters Patent, is—

1. The combination of pivoted hangers, the counter-shaft mounted therein, arms upon said hangers, a rock shaft having arms or cranks mounted in said arms, links connecting said rock-shaft to fixed points, and a lever whereby said rock-shaft may be rocked, and the hangers thus swung on their pivots, thereby tightening or slackening the belts, substantially as set forth.

2. The combination of pivoted hangers, a counter-shaft mounted therein, arms extending from said hangers, a rock-shaft having arms or cranks and mounted in said arms, links connecting said rock-shaft to fixed points, a lever whereby said rock-shaft is operated, a belt shifter, and connections between said lever and said belt shifter, whereby the belts may be slackened or tightened and shifted at one operation, substantially as set forth.

3. The combination of the pivoted hangers C having arms C' and C^2 , the rock-shaft D , the links D' whereby it is suspended, the belt shifter, the lever D^2 , an arm X^2 and the links and bell-crank levers D^3 D^4 and D^5 , said several parts being arranged and operating substantially as set forth.

4. The combination, in a belt slackener and tightener, of the hangers C secured to the ceiling above the mechanism of the tightener, and consisting of two parts united by pivots c , the lower or pivoted portion whereof is extended around to one side of the counter-shaft, which is thus enabled to be located substantially below said pivots, said counter-shaft, adjustable bearings on said hanger for

said counter-shaft, a rock-shaft mounted in bearings on the free end of the swinging hanging parts, supporting connections for said free ends, and means for moving said rock-shaft and thereby shifting the position of said pivoted hanger parts, substantially as and for the purposes set forth.

5 5. The combination, in a belt slackener and tightener, with the counter-shaft carrying the intermediate pulleys, of hangers for said counter-shaft formed in two parts and united by pivots *c*, the upper or stationary part being secured to the ceiling or frame-work, and the lower part being extended out to one side
10 and thence down and under said counter-shaft, whereby said counter-shaft is enabled

to be positioned substantially under the pivots of said hangers, substantially as set forth.

6. The combination, in a belt slackener and tightener, of the pivoted hangers carrying the counter-shaft, a rock shaft mounted in arms on said hangers, a lever, and crank arms on said rock shaft which are adjustable thereon, and suspending links attached to said crank arms, substantially as set forth.

In witness whereof I have hereunto set my hand and seal, at Indianapolis, Indiana, this 1st day of July, A. D. 1893.

THEODORE F. VANDEGRIFT. [L. s.]

Witnesses:

CHESTER BRADFORD,
JAMES A. WALSH.